

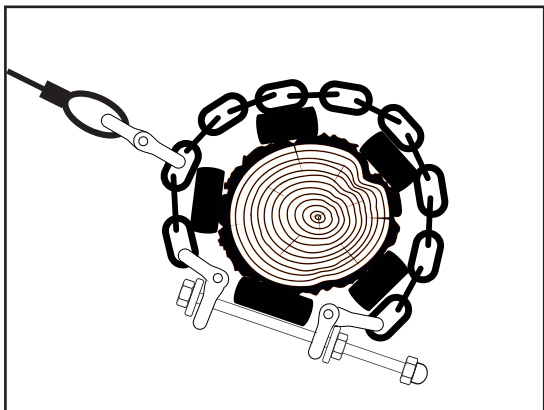

# ZAZA2 CT

## CHAIN TENSIONER



### ADVANTAGES

- Easy to install
- Adaptable to the growth of the tree

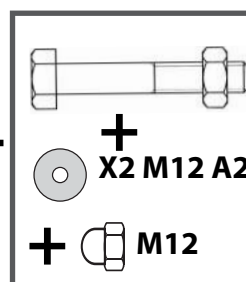
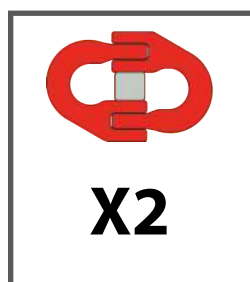
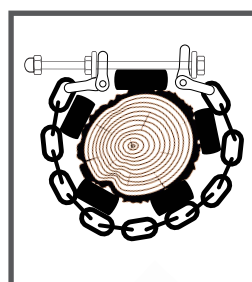
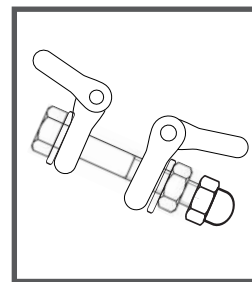
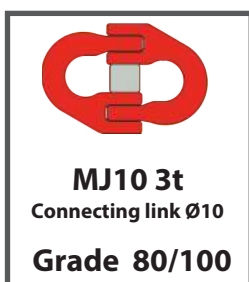
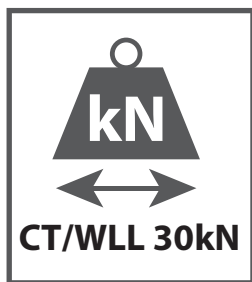

length of the chain = (perimeter of the tree + wedges) - 150 mm



Disable deformed, worn or cracked chains

**Opération 1**

**ASSEMBLY**

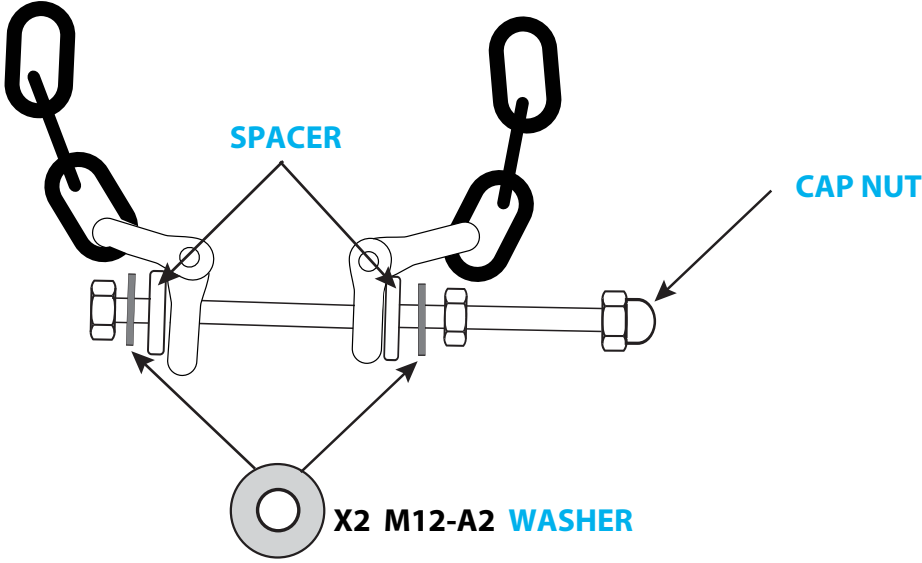

**Opération 2**

**RECOMMANDATION OF ASSEMBLY**

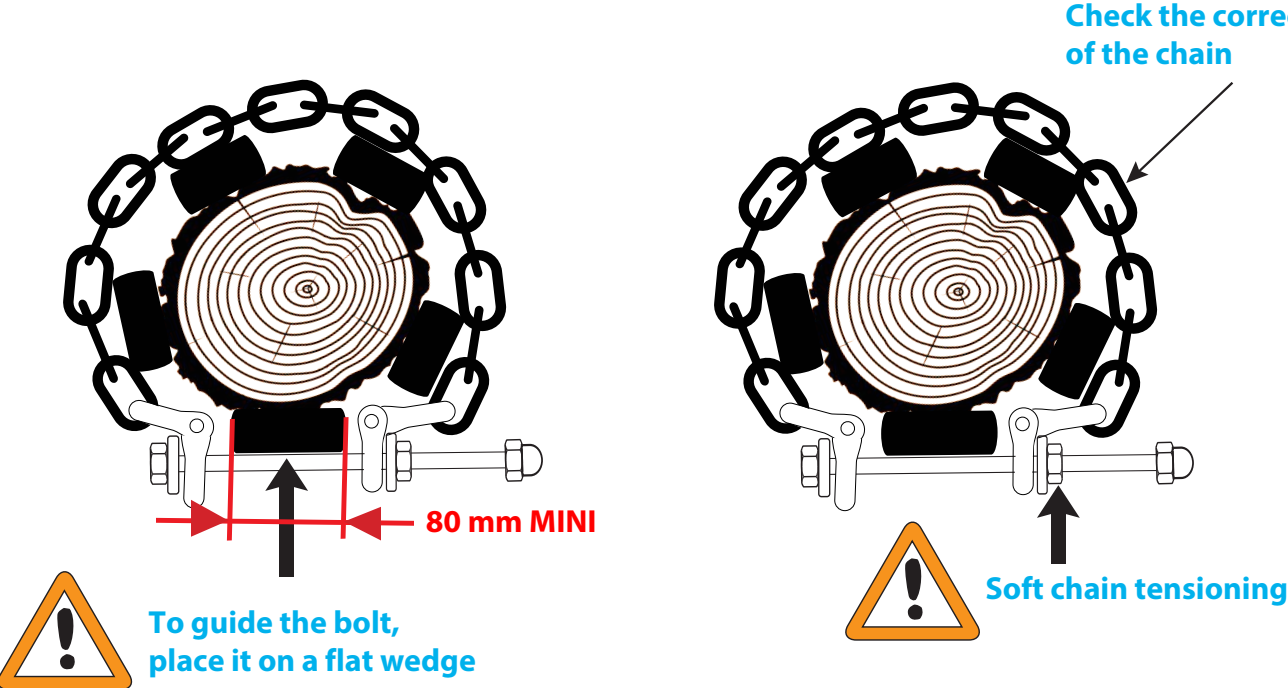

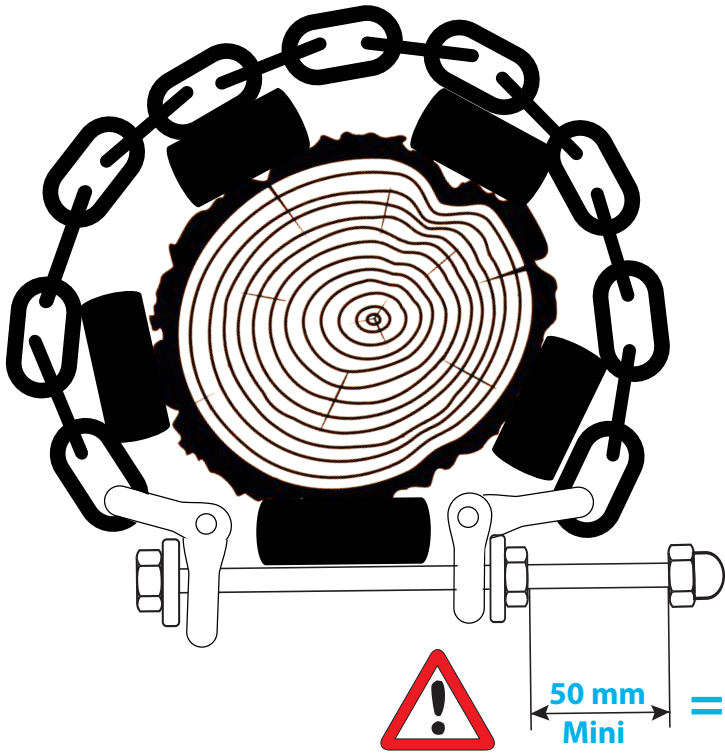

**Opération 3**

**CONNECTION SLING / CHAIN**

**STANDARDS OF ASSEMBLY**



EN 15567-1  
EN 13411-1/7  
STANDARDS - ACCT

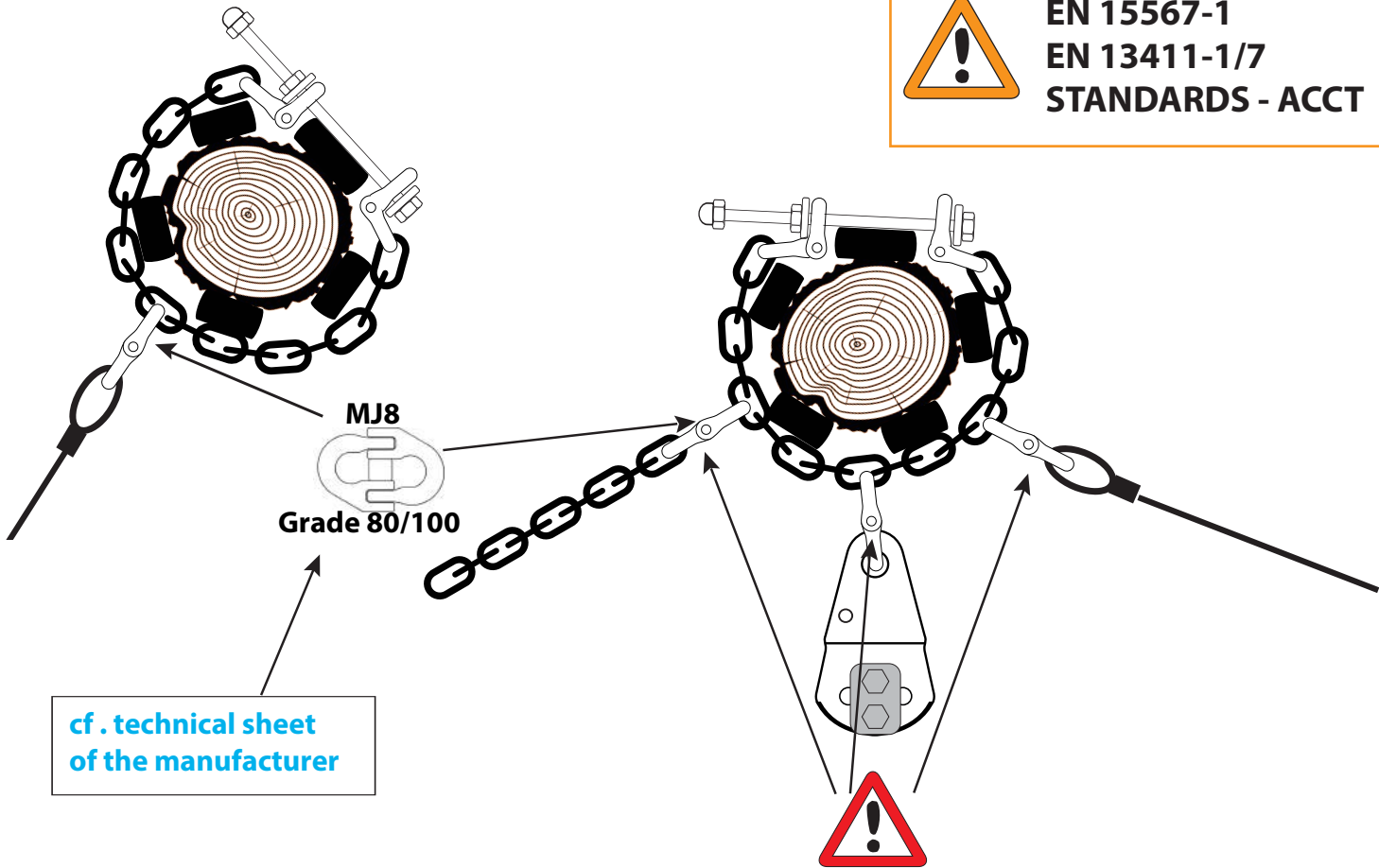

cf. technical sheet  
of the manufacturer

**MULTIPLE CONNECTIONS → SUM OF THE LOAD = MAX 30 kN**

## ADVICE

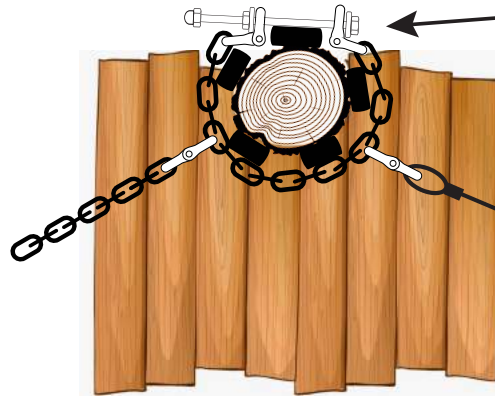

Position the ZAZA2 CT out of contact with the user

## STANDARDS OF ASSEMBLY



EN 15567-1  
EN 13411-1/7  
STANDARDS - ACCT

## TRICK!



ZAZA2 PC with CLAMP